

## Handwheels

Aluminum, Powder Coated, for Linear Actuators

### SPECIFICATION

#### Types

- Type **A**: Without handle
- Type **R**: With revolving handle
- Type **RU**: With revolving retractable handle

Aluminum die casting

- Machined hub
- Turned rim
- Powder coated
- Black, RAL 9005, textured finish **SW**

Concentricity and axial run-out tolerance of the rim < 0.4

Revolving Handles GN 798.2 (see page 578) / Retractable Handles GN 798.3 (see page 586) / Revolving Cylinder Handles GN 599.5

### INFORMATION

Handwheels GN 9234 are intended for use with linear actuators and are designed as disk or spoked handwheels, depending on their size.

The applied torque is transmitted by means of a parallel key, and the handwheel is secured axially with the supplied grub screw. The handwheels can be ordered without handles, with revolving handles or with revolving retractable handles.

### TECHNICAL INFORMATION

- Keyway DIN 6885 (see page A16)
- Cross Holes GN 110 (see page A17)
- ISO-Fundamental Tolerances (see page A21)



reddot design award

Disk handwheel

Spoked handwheel

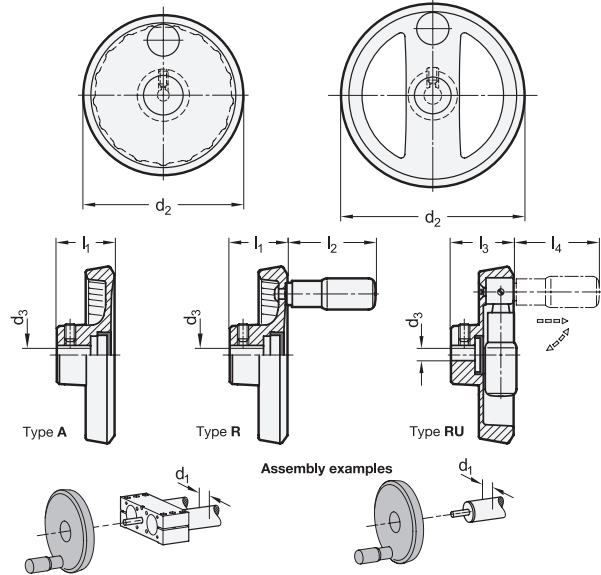

### GN 9234-A

Description	d <sub>1</sub>	d <sub>2</sub> Disk handwheel	d <sub>2</sub> Spoked handwheel	d <sub>3</sub> H7 Bore	l <sub>1</sub> ≈	⚖
GN 9234-18-50-A-SW	18	50	-	6	26	66
GN 9234-18-80-A-SW	18	80	-	6	26	105
GN 9234-25-63-A-SW	25	63	-	8	27	80
GN 9234-25-100-A-SW	25	100	-	8	30	130
GN 9234-30-63-A-SW	30	63	-	8	27	104
GN 9234-30-100-A-SW	30	100	-	8	30	158
GN 9234-40-100-A-SW	40	100	-	12	30	155
GN 9234-40-125-A-SW	40	-	125	12	33.5	260
GN 9234-50-140-A-SW	50	-	140	12	36.5	351
GN 9234-60-160-A-SW	60	-	160	14	39.5	491

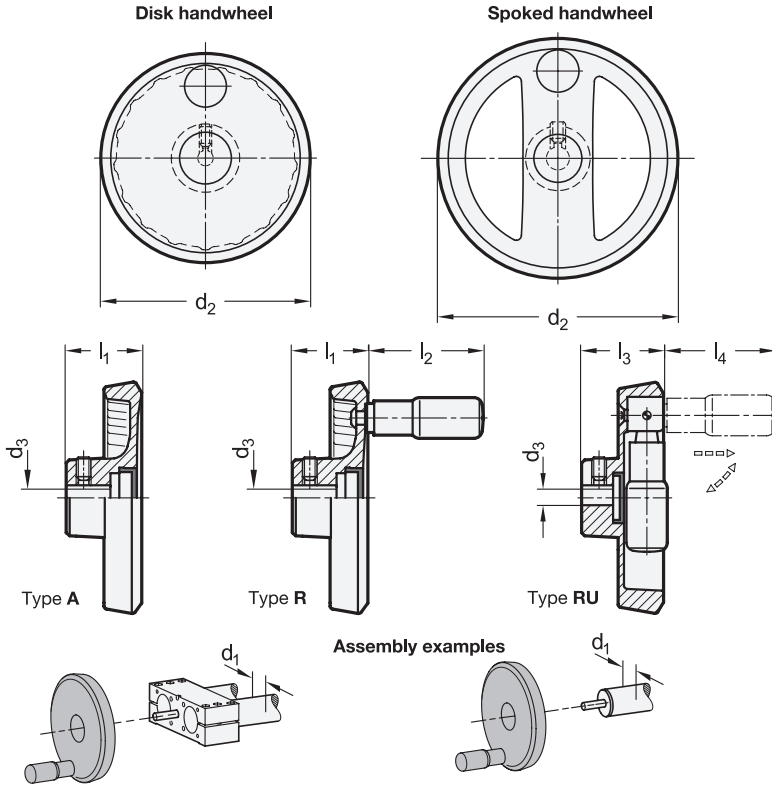

GN 9234-R

Description	d1	d2 Disk handwheel	d2 Spoked handwheel	d3 H7 Bore	l1 ≈	l2 ≈	Ø Handle GN 599.5	Ø Handle GN 798.2	⚖
GN 9234-18-50-R-SW	18	50	-	6	26	20	13	-	77
GN 9234-18-80-R-SW	18	80	-	6	26	43.5	-	16	132
GN 9234-25-63-R-SW	25	63	-	8	27	20	13	-	85
GN 9234-25-100-R-SW	25	100	-	8	30	58	-	18	135
GN 9234-30-63-R-SW	30	63	-	8	27	20	13	-	115
GN 9234-30-100-R-SW	30	100	-	8	30	58	-	18	189
GN 9234-40-100-R-SW	40	100	-	12	30	58	-	18	205
GN 9234-40-125-R-SW	40	-	125	12	33.5	61.5	-	22	339
GN 9234-50-140-R-SW	50	-	140	12	36.5	76.5	-	24	437
GN 9234-60-160-R-SW	60	-	160	14	39.5	76.5	-	24	577

GN 9234-RU

Description	d1	d2 Disk handwheel	d2 Spoked handwheel	d3 H7 Bore	l3 ≈	l4 ≈	Ø Handle GN 798.3	⚖
GN 9234-25-100-RU-SW	25	100	-	8	39	56.5	18	245
GN 9234-30-100-RU-SW	30	100	-	8	39	56.5	18	260
GN 9234-40-100-RU-SW	40	100	-	12	39	56.5	18	305
GN 9234-40-125-RU-SW	40	-	125	12	45	60.5	22	461
GN 9234-50-140-RU-SW	50	-	140	12	47	75.5	24	609
GN 9234-60-160-RU-SW	60	-	160	14	48	75.5	24	729

